



Optimizing your drive!

RHF-5P XXX-400-50-YY-Z



Main

Product type	The REVCON Harmonic Filter - RHF-5P - reduces the THDi of nonlinear loads from typically 35% to significantly below 5% even under realistic ambient conditions. Due to the use of a two-stage filter module, the RHF is able to achieve a significant higher efficiency and a smooth damping across the full harmonic spectrum.
Performance	5P = <5% THDi, (3% THDi typical performance)
Motor Power [XXX]	4kW - 630kW
Degree of Protection [YY] and design [Z]	C = Compact:4kW - 280kW (IP20) S = Split: 315kW - 630kW panel mount design (IP00). E = Enclosed: 315kW - 630kW panel mount (var. IP ratings)
Design	High efficient double-stage filter (no RC damping)
Supply voltage	380-415V (+10% / -15%) 50Hz (+/- 2%)
Power factor	1 at nominal power
Overload	1.5
Efficiency	>98.4% - 99.4% (efficiency depend on rating and load)
Standards and requirements	IEC/EN 61000-2-2 / -4 IEC/EN 61000-3-2 / -4 / -12 IEEE 519-2014 Engineering Recommendation G5-5
Humidity	Humidity class F without condensation 5.....85% - Class 3K3 (non-condensing) during operation
Ambient temp.	min. 5°C (41°F) max. 45 °C (113°F) derating above 45°C (113°F) = -1.5%/K (up to 60°C (140°F))
Altitude	<1000m derating above 1000m: -5%/1000m (up to 4000m)

Applications

Water and wastewater treatment
HVAC / Pumps and Fans (VFD)
Industrial/ Factory Process (VFD)
DC charger
Buildings / IEEE 519-2014 requirement
Marine
Symetrical load multiple VFD



General Industry



Marine



Oil & Gas



Water Treatment



Data Center



Buildings

Harmonic current on standard 6-Pulse VFD

Systems with significant part of non linear loads will cause harmonic distortion on the voltage supply, which may damage equipment and supply transformer. **REVCON Harmonic Filter – RHF** - reduces the THDi of nonlinear loads from typically 35% to significantly below 5% (RHF-5P) or below 8% (RHF-8P) even under realistic ambient conditions.

Due to the use of a two-stage filter module, the RHF is able to achieve a significant higher efficiency and a smooth damping across the full harmonic spectrum.

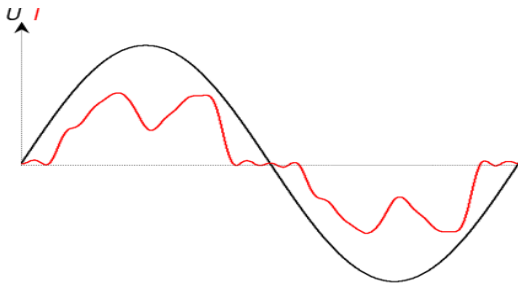

Typical input current shape when using a standard 6-pulse drive

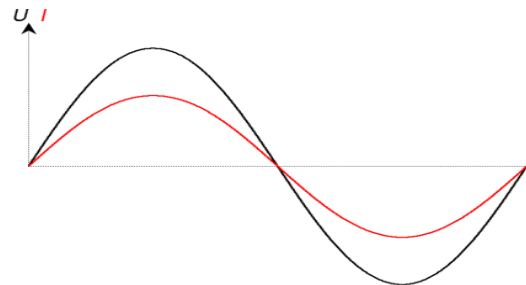

Typical input current shape when using a standard 6-pulse drive with RHF harmonic filter

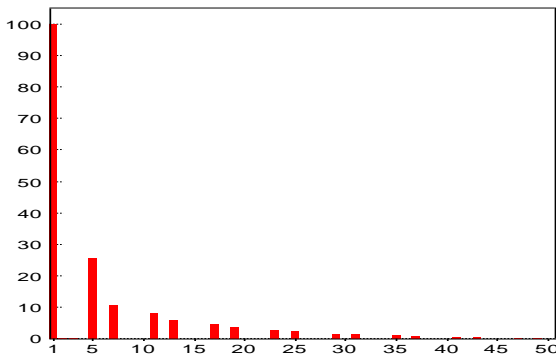

Typical harmonic current spectrum when using a standard 6-pulse drive with DC-Choke

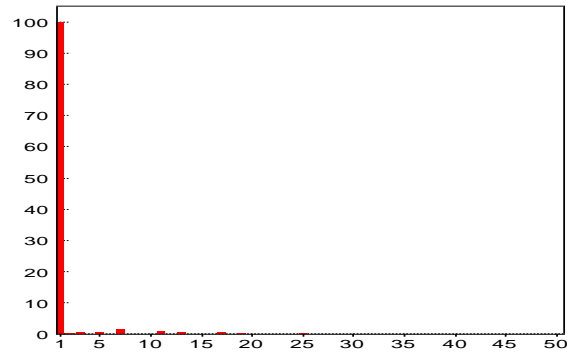

Typical harmonic current shape when using a standard 6-pulse drive with RHF-5P

Working Principle RHF-5P - REVCON Passive Harmonic Filter

The following pictures describe the RHF-5P hardware configuration. Instead of using a simple drain circuit (Simple PHF) for the 5th Harmonic, the RHF-5P use a two-stage filter which enables the following advantages:

1. Performance: The RHF is designed to reach its stated performance in the field and not defined for unique simulated conditions. The double stage filter offers a smooth damping of all Harmonics, instead of focusing on the 5th Harmonic.
2. Full Drive Power: The RHF allows for 100% DC Bus voltage at 100% drive load. This avoid further calculations and de-rating of the drive. (Drives connected to Simple Harmonic Filter may have up to 7% lower power ratings!)
3. Efficiency: Simple Harmonic Filter may add RC circuits in order to reach specified performance which leads to a significant lower efficiency. The RHF-5P double stage harmonic filter cause up to 70% less power loss than comparable <5% THDi solutions.

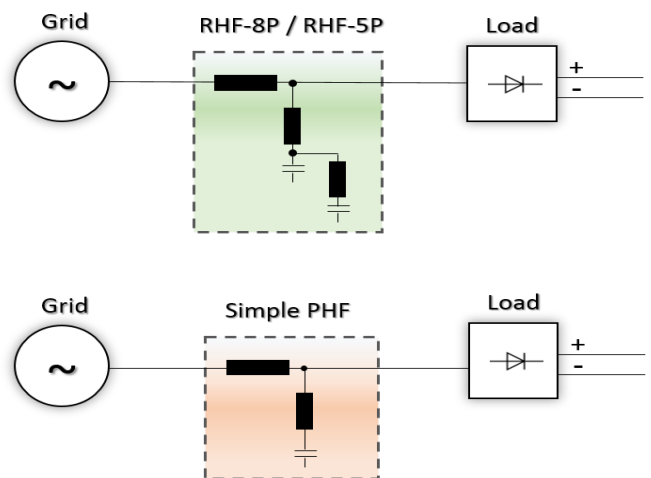

Available size for 3 Phase supply / 400V / 50Hz / 5% THDi

Compact range - All filter components combined in one enclosure							
Revcon Filter RHF-5P	Order code	Input current [A]	max current [A]	Motor size*	Filter encl.	Weight [kg]	Power- loss [W]
RHF-5P 4.0-400-50-20-C	25002002	7.3	11	4.0kW	X1	18	102
RHF-5P 5.5-400-50-20-C	25002003	10	15	5.5kW	X1	18	131
RHF-5P 7.5-400-50-20-C	25002004	14	21	7.5kW	X1	19	169
RHF-5P 11-400-50-20-C	25002005	22	33	11kW	X2	29	243
RHF-5P 15-400-50-20-C	25002006	27	41	15kW	X2	33	283
RHF-5P 18.5-400-50-20-C	25002007	32	48	18.5kW	X3	52	305
RHF-5P 22-400-50-20-C	25002008	38	57	22kW	X3	53	366
RHF-5P 30-400-50-20-C	25002009	52	78	30kW	X3	58	452
RHF-5P 37-400-50-20-C	25002010	63	95	37kW	X4	76	542
RHF-5P 45-400-50-20-C	25002011	76	114	45kW	X4	98	658
RHF-5P 55-400-50-20-C	25002012	92	138	55kW	X5	104	717
RHF-5P 75-400-50-20-C	25002013	125	188	75kW	X5	106	812
RHF-5P 90-400-50-20-C	25002014	150	225	90kW	X6	126	932
RHF-5P 110-400-50-20-C	25002015	182	273	110kW	X6	135	1020
RHF-5P 132-400-50-20-C	25002016	217	326	132kW	X7	172	1134
RHF-5P 160-400-50-20-C	25002017	262	393	160kW	X7	206	1228
RHF-5P 185-400-50-20-C	25002018	304	456	185kW	X8	221	1346
RHF-5P 200-400-50-20-C	25002019	328	492	200kW	X8	230	1450
RHF-5P 220-400-50-20-C	25002020	360	540	220kW	X8	265	1500
RHF-5P 250-400-50-20-C	25002021	410	615	250kW	X8	272	1530
RHF-5P 280-400-50-20-C	25002022	460	690	280kW	X8	273	1718

Split range - Filter consisting of line choke and filter enclosure X9-X11								
Revcon Filter RHF-5P	Order code	Input current [A]	max current [A]	Motor size*	Filter encl.	Weight		Power- loss [W]
						Filter Modul [Kg]	line inductor [Kg]	
RHF-5P 315-400-50-00-S	25002023	520	780	315kW	X9	170	200	2080
RHF-5P 355-400-50-00-S	25002024	600	900	355kW	X10	240	225	2390
RHF-5P 400-400-50-00-S	25002025	650	975	400kW	X10	240	240	2530
RHF-5P 450-400-50-00-S	25002026	720	1080	450kW	X10	270	260	2778
RHF-5P 500-400-50-00-S	25002027	830	1245	500kW	X10	270	285	2928
RHF-5P 560-400-50-00-S	25002028	920	1380	560kW	X10	315	310	3150
RHF-5P 630-400-50-00-S	25002029	1030	1545	630kW	X10	315	330	3330

*The corresponding motor size listed in this file is based on the following technical specification:
Motor is IE3 6-Pol or lower. VFD efficiency is 97% or higher and have internal DC-Choke of 3% or higher.

Overview enclosure size compact execution

Enclosure Size	Height A [mm]	Width B [mm]	Depth C [mm]	Height MH [mm]	Width MW [mm]	Mount MS [mm]
X1	322	196	205	278	163	6.8
X2	454	232	248	382	205	6,8
X3	592	378	245	523	353	9
X4	621	378	338	554	353	9
X5	736	418	333	661	392	9
X6	764	418	405	661	392	9
X7	957	468	451	780	443	9
X8	957	468	515	780	443	9

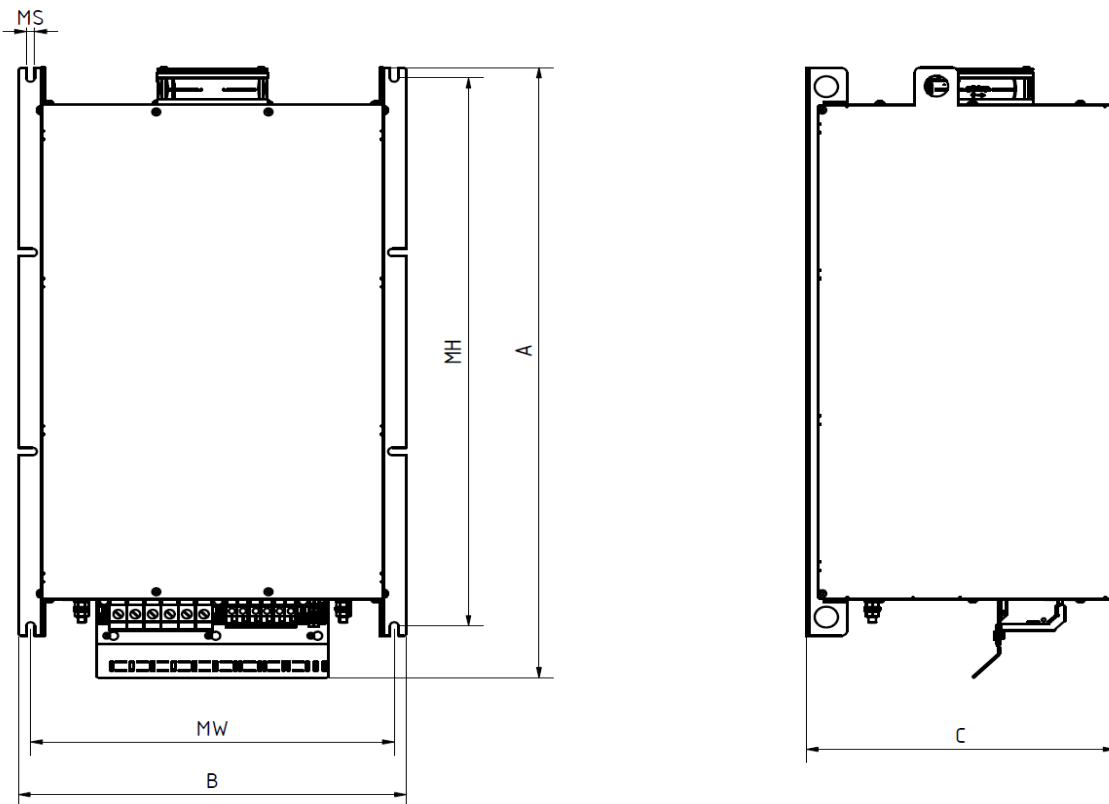

Overview enclosure size separate execution

Enclosure Size	Height A [mm]	Width B [mm]	Depth C [mm]	Height MH [mm]	Width MW [mm]	Mount MS [mm]
X9	1100	274	510	1052	211	9
X10	1100	474	510	1050	130	9
X11	1100	674	510	1050	200	9

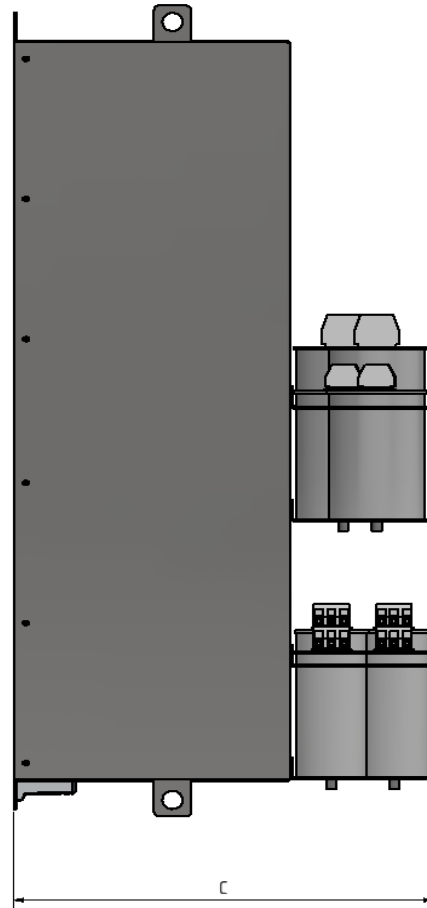
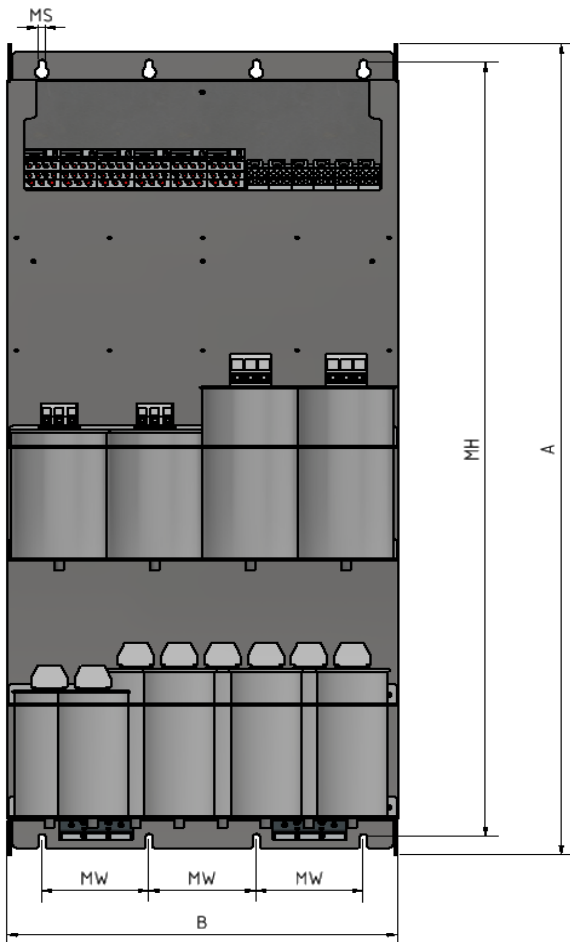

Overview line inductor size separate execution

line inductor type	Width A [mm]	Height B [mm]	Depth 1 C [mm]	Depth 2 D [mm]	bus bars MH E [mm]	Width MW F [mm]	depth MW G [mm]	bus bars MW H [mm]	Mount MS I/J [mm]
RHF-5P 315-400-50-00-S	510	540	280	400	380	430	240	170	14
RHF-5P 355-400-50-00-S	570	620	230	360	420	520	165	200	14
RHF-5P 400-400-50-00-S	600	620	240	370	420	520	175	200	14
RHF-5P 450-400-50-00-S	600	620	255	385	420	520	190	200	14
RHF-5P 500-400-50-00-S	600	620	270	400	420	520	205	200	14
RHF-5P 560-400-50-00-S	600	620	290	420	420	520	225	200	14
RHF-5P 630-400-50-00-S	600	640	300	440	420	520	235	200	14

